

# TECHNICAL DATA

COLD PLANNER (Stage V / TIER 4f)

BM 1000/35-2, BM 1200/35-2, BM 1300/35-2

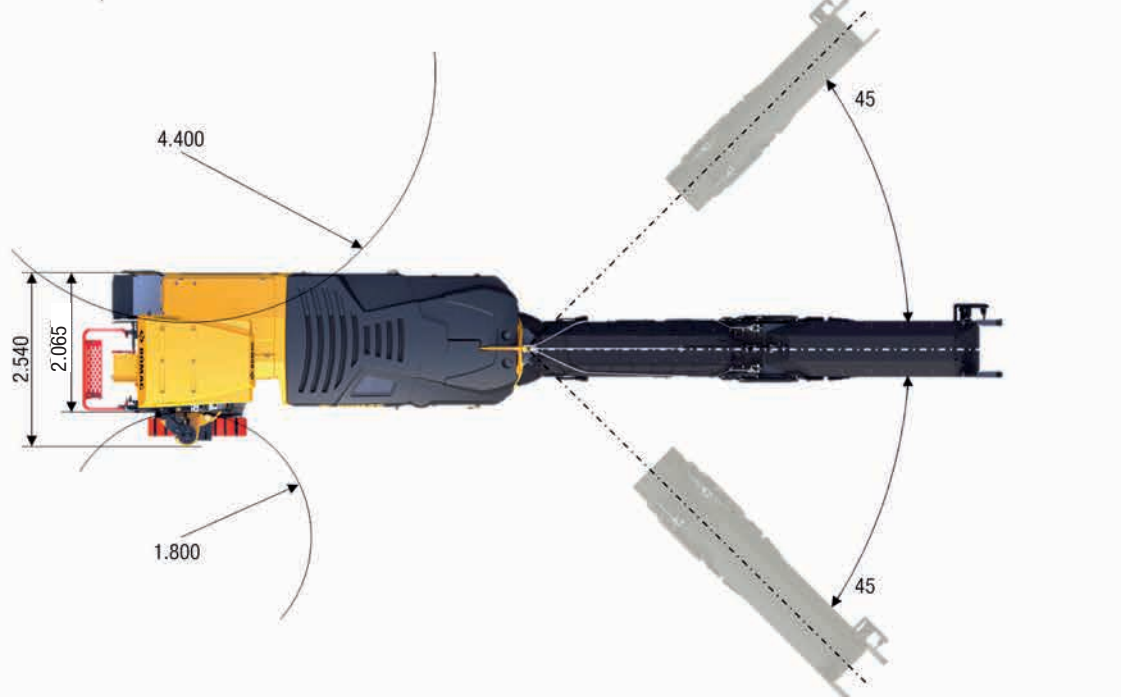

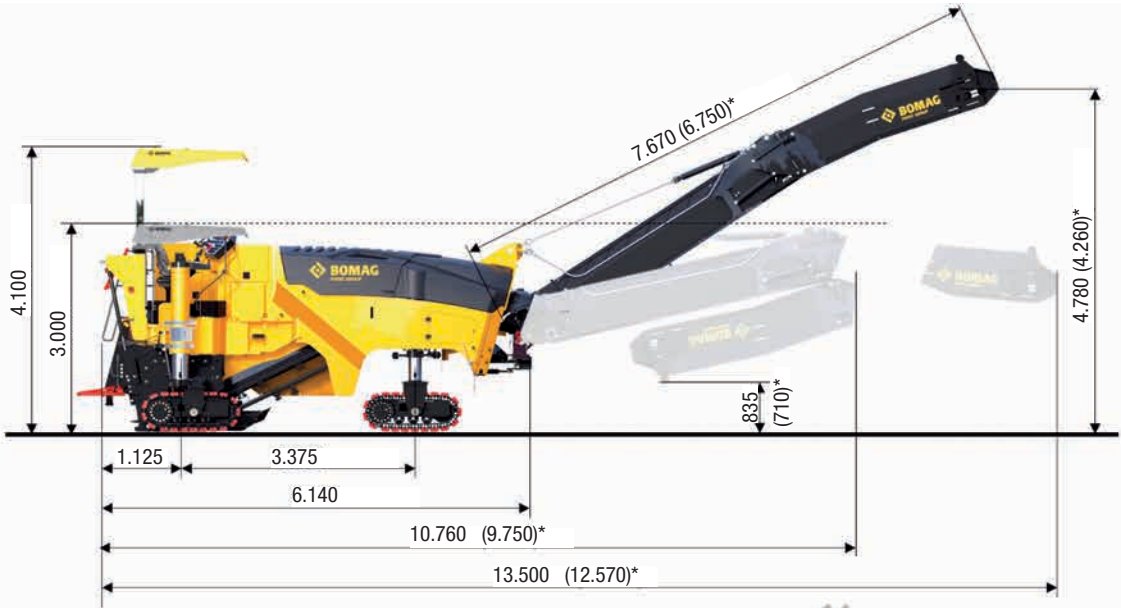

**BM 1200 & BM 1300**



\* FO22

## Technical data

### Milling drum

	<b>BOMAG BM 1000/35-2</b>	<b>BOMAG BM 1200/35-2</b>	<b>BOMAG BM 1300/35-2</b>
Milling width max .....	1000	1200	1300
Milling depth .....	0–330	0–330	0–330
Milling line distance .....	15	15	15
Cutting diameter .....	980	980	980
Number of cutting tools .....	99	115	121
Milling speed .....	variable, 85, 95 and 107	variable, 85, 95 and 107	variable, 85, 95 and 107

### Drive

Engine manufacturer .....	MTU (Mercedes)	MTU (Mercedes)	MTU (Mercedes)
Type .....	Series 1000 6R	Series 1000 6R	Series 1000 6R
Exhaust classification .....	STAGE V / TIER 4f	STAGE V / TIER 4f	STAGE V / TIER 4f
Cooling system .....	Fluid	Fluid	Fluid
Number of cylinders/displacement .....	6/7,700	6/7,700	6/7,700
Power .....	260/350	260/350	260/350
Rated speed .....	2200	2200	2200
Max. torque .....	1400	1400	1400
Fuel consumption at nominal power .....	210	210	210
Fuel consumption with the construction mix .....	26	26	26
Generator .....	28/150	28/150	28/150
Battery .....	2 x 12 / 155	2 x 12 / 155	2 x 12 / 155

### Travel characteristics

Travel speed .....	0–7.5	0–7.5	0–7.5
Working speed .....	0–50	0–50	0–50
Track chains, L x W x H .....	1425 x 268 x 570	1425 x 268 x 570	1425 x 268 x 570

### Filling capacities

Fuel .....	600	600	600
Water .....	1400	1400	1400
Hydraulic system .....	180	180	180
AdBlue .....	40	40	40

### Loading system

Width of conveyor belt, inner/outer .....	650/600	650/600	650/600
Theoretic loading capacity .....	180	180	180
Discharge height .....	5700	5700	5700

### Machine weights

Max. operating weight (incl. options) .....	24	25	25.5
Operating weight CECE .....	20.4	21.4	21.9
Basic weight .....	19.4	20.4	20.9

### Extra weights options

Weather protection roof .....	205	205	205
Dust extraction .....	140	140	140
Scraper, split .....	200	200	200
Quick-change milling drum .....	110	120	130
Fine milling drum LA8 .....	300	300	300
Ballast 1, frame .....	1150	1030	1030
Ballast 2, milling box .....	440	440	440

Technical modifications reserved. Machines may be shown with options. The actual machine weight depends on the respective configuration.

## Standard equipment

### Milling technology

- Milling drum LA15
- BOMAG BMS 15 exchange holder system
- 3 Milling drum speeds
- Proportionally adjustable water quantity
- Automatic water saving detection
- Water filling pump
- Wear-free, digital milling depth indicator
- Proportional milling depth adjustment
- Two proportional height adjustment speed ranges
- Hydraulically operated side plates
- Hydraulically operated hold-down
- Scraper with adjustable scraper pressure
- Right-hand side plate for quick milling drum changes
- Automatic power limit control
- Automatic traction control
- Hydraulically foldable discharge belt

### Drives

- Track chain drive with 4 chains
- Swivel mechanism: Full automatic swivelling of the rear right chain with 5,000 hrs./ 60 M warranty
- Steered rear right chain
- Infinitely variable transport speed range
- Infinitely variable milling speed
- Mechanical milling drive

### Ease of operation

- Fully vibration-isolated driver's stand
- Comfortable work area for operation from a seated position
- Ergonomic comfort seat, which can be rotated 45° in two directions
- Ergonomically adjustable steering column
- Height-adjustable arm rest with an integrated control unit
- Self-explanatory and clearly arranged control panel
- Spacious storage compartments at ground level
- High performance 3-way water pump
- Group placement of service and maintenance points
- Secure and conveniently accessible service and maintenance points

### Safety & environmental protection

- Package for noise elimination to a whisper-quiet level
- Water-cooled engine of the latest

## Exhaust classification

- Variably positionable optional head lights
- Flashing beacon
- Rear-view mirror
- Backup protection
- Vandal-proof covers for the control units

## Optional equipment

### Basic machine

- Weather protection roof
- High pressure cleaner
- Dust extraction
- ION DUST SHIELD
- Auxiliary drive for tool change
- StvZO lighting
- Optional head lights, attachable
- Optional head lights, magnetic base
- Ballasting
- Seat heating
- Special paintwork
- Biodegradable hydraulic oil
- Hydraulically folding discharge belt, short
- Maintenance seat
- Access ladder
- Storage package
- Holder package for shovel, spray can, etc.

### Milling technology

- Milling drum 600 LA15
- Milling drum 900 LA15
- Milling drum 1000 LA15
- Milling drum 1200 LA15
- Milling drum 1300 LA15
- Fine milling drum 1000 LA8
- Fine milling drum 1200 LA8
- Fine milling drum 1300 LA8
- Fine milling drum 1000 LA6x2
- POWER DRUM 1000 LA22
- POWER DRUM 1200 LA22
- POWER DRUM 1300 LA22
- Split scraper
- Counter bearing for SW milling drum

### Levelling systems and electronic aids

- BOMAG Easy Level; levelling, 2 sides + cross slope
- Mechanical height indicator on the rear lifting columns
- Camera surveillance
- BOMAG TELEMATIC

